

Product Overview:

The L200A pressure sensitive label applicator is the proven, economical solution designed to meet the demands of expanding labeling requirements and higher production speeds. Durable, industrial-grade construction assures you that the L200A label applicator will provide around-the-clock operation you can depend on. The easy to use operator interface allows for quick changes to label speeds and position. Flexible design features and multiple application options allow you to easily tailor the L200A to cover your specific labeling needs.

Standard Features:

- On board diagnostics
- Product recipe capabilities
- On-the-fly label adjustments
- No tool required label changeover
- Streamline footprint
- Assortment of modules including Tamp
- Right-hand and left-hand

Available Options:

- Tamp-On, Blow-On, Tamp-Blow and Wipe-On modules
- Swing arm pallet labeler
- Wipe-On brush accessory kits
- Harsh environment head
- Line encoder kit upgrades
- Label low level sensor & beacon fault upgrades
- Adjustable stands and machine mount supports

Labeling Rate (PPM)	150ppm to 300ppm *
Label Head Speed	1,000"/min (423mm/sec)
Accuracy	± 0.02" (± 0.5mm)
Controls	Programmable Logic Controller
Label Drive Motor	High Torque Micro Stepper
Unwind Roll Diameter	12" (305mm) OD x 3" (76mm) ID
Label Detection	Photo Electric
Power Requirements	115/230VAC, 50/60 Hz, 10 Amp
Environment	41-104°F (5-40°C), 25-85% relative humidity

*Dependent upon label and application

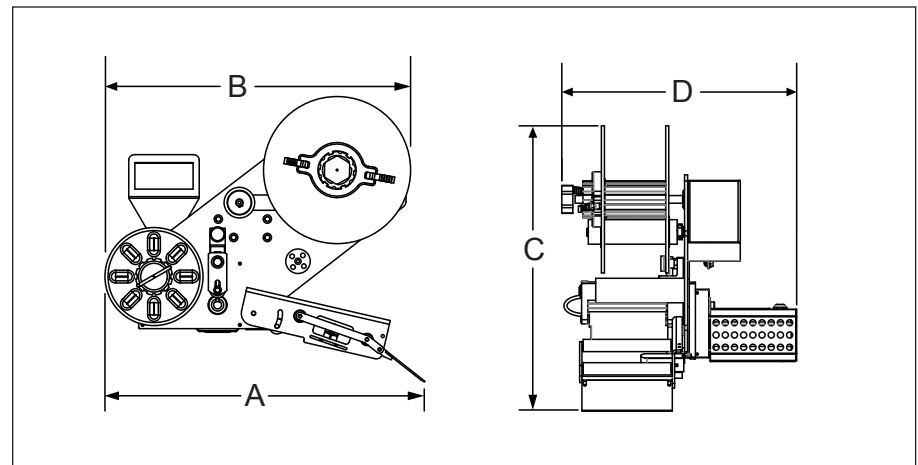

Product Specifications		ANSI	Metric
A	Length - Rewind Wheel to Peeler Plate	26.1"	663mm
B	Length - Rewind Wheel to Unwind Wheel	24.9"	633mm
C	Applicator Height	23.3"	592mm
D	Applicator Depth	19.2"	488mm

Headquarters
13129 Airpark Dr.
Suite 120
Elkwood, VA 22718
540.829.2564 t
800.368.3582 t
540.829.1726 f

Sales Office
1445 Brookville Way
Suite F
Indianapolis, IN 46239
317.322.0754 t
800.368.3582 t
317.322.0794 f

Manufacturing Office
291 Dillard Road
Madison Heights, VA
24572
434.929.4746 t
800.543.0915 t
434.929.4959 f

www.ShibuyaHoppmann.com | sales@ShibuyaHoppmann.com

Shibuya Hoppmann Corporation strives to improve its products and reserves the right to change or discontinue specifications & designs shown in this brochure without notice and without incurring obligation. Revised: 12/11.